



GAI-TRONICS®
A HUBBELL COMPANY

Model 495-001 Mine Dial/Page Phone Interface Cabinet

Confidentiality Notice

This manual is provided solely as an operational, installation, and maintenance guide and contains sensitive business and technical information that is confidential and proprietary to GAI-Tronics. GAI-Tronics retains all intellectual property and other rights in or to the information contained herein, and such information may only be used in connection with the operation of your GAI-Tronics product or system. This manual may not be disclosed in any form, in whole or in part, directly or indirectly, to any third party.

General Information

The GAI-Tronics Mine Dial/Page Phone system provides the convenience of a telephone station plus additional paging capabilities in gaseous or dusty locations too hazardous for standard telephone equipment.

The system is used in conjunction with Touch Tone (DTMF) operated public telephone exchange or a private branch exchange (PABX). Each station in the system is made up of two components: a 491 Series Mine Dial/Page Phone, and a Model 495-001 Mine Dial/Page Phone Interface Cabinet located outside the hazardous area. The Model 495-001 Interface Cabinet is electrically connected between the station and the telephone switchboard. Each station is connected to a separate line of the telephone exchange. A simplified diagram for a Mine Dial/Page Phone system is shown in Figure 1.

A person at any properly installed GAI-Tronics 491 Series Mine Dial/Page Phone station can dial any other such station or any other conventional telephone connected to that switchboard. If the switchboard is tied into the public telephone system, calls can be made to, and received from any public telephone.

In keeping with MSHA regulations, at least one GAI-Tronics 491 Series Mine Dial/Page Phone station for each interface cabinet must be installed on the outside of a coal mine.

Principles of Operation

Each 491 Series Mine Dial/Page Phone is normally connected by an individual pair of wires to the Model 495-001 Interface Cabinet, but up to five phones can be connected in parallel. (**NOTE:** This system is designed to operate with only one station off hook). Outgoing calls can be made from any station and answered at any station - the same as when extension telephones are used. It is not possible to dial calls between stations on the same line.

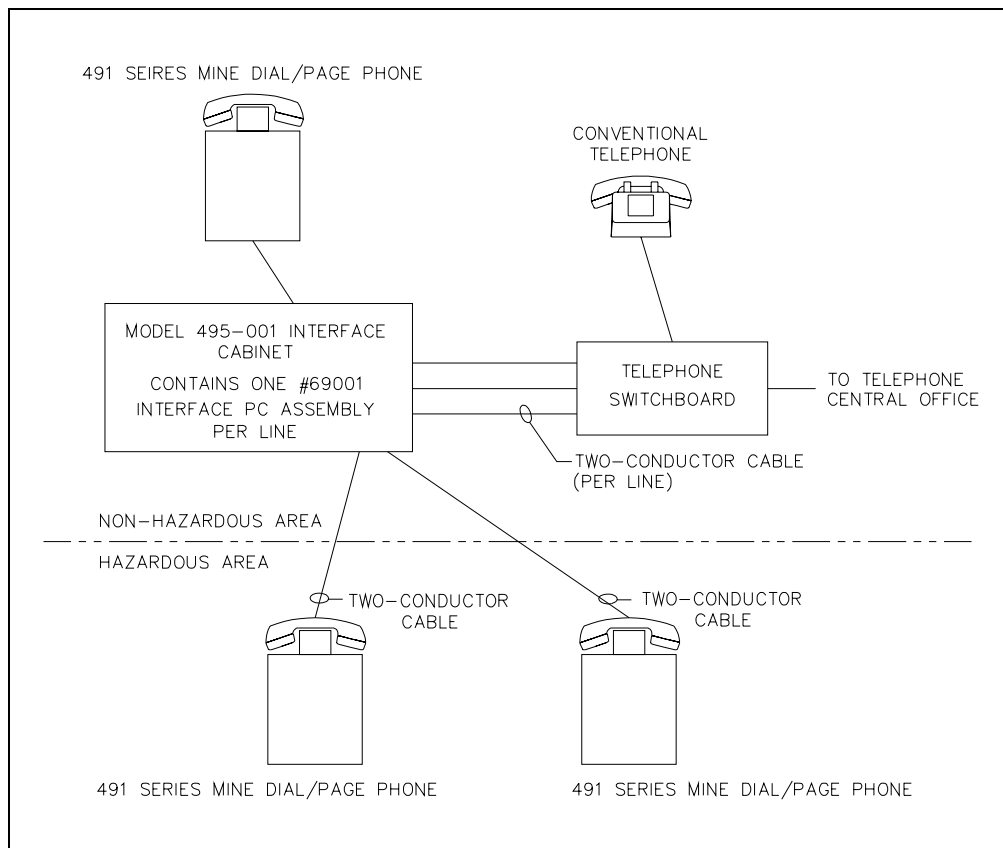

Figure 1. Simplified System Diagram

Physical Description of the Equipment

A GAI-Tronics Mine Dial/Page Phone system consists of one Model 495-001 Interface Cabinet plus as many 491 Series Mine Dial/Page Phone stations as required. The 491 Series Mine Dial/Page Phone is housed within corrosion-resistant, non-metallic enclosure. The handset rests in a combination cradle and handle on top of the enclosure.

Each 491 Series station requires one Telephone Line Interface card, which measures approximately 13 × 10 × 7 inches (33 × 25.4 × 17.8 cm). The Model 495-001 Phone Interface Cabinet is 77 inches (1.96 m) high and has the capacity to support 80 stations. See Figure 2.

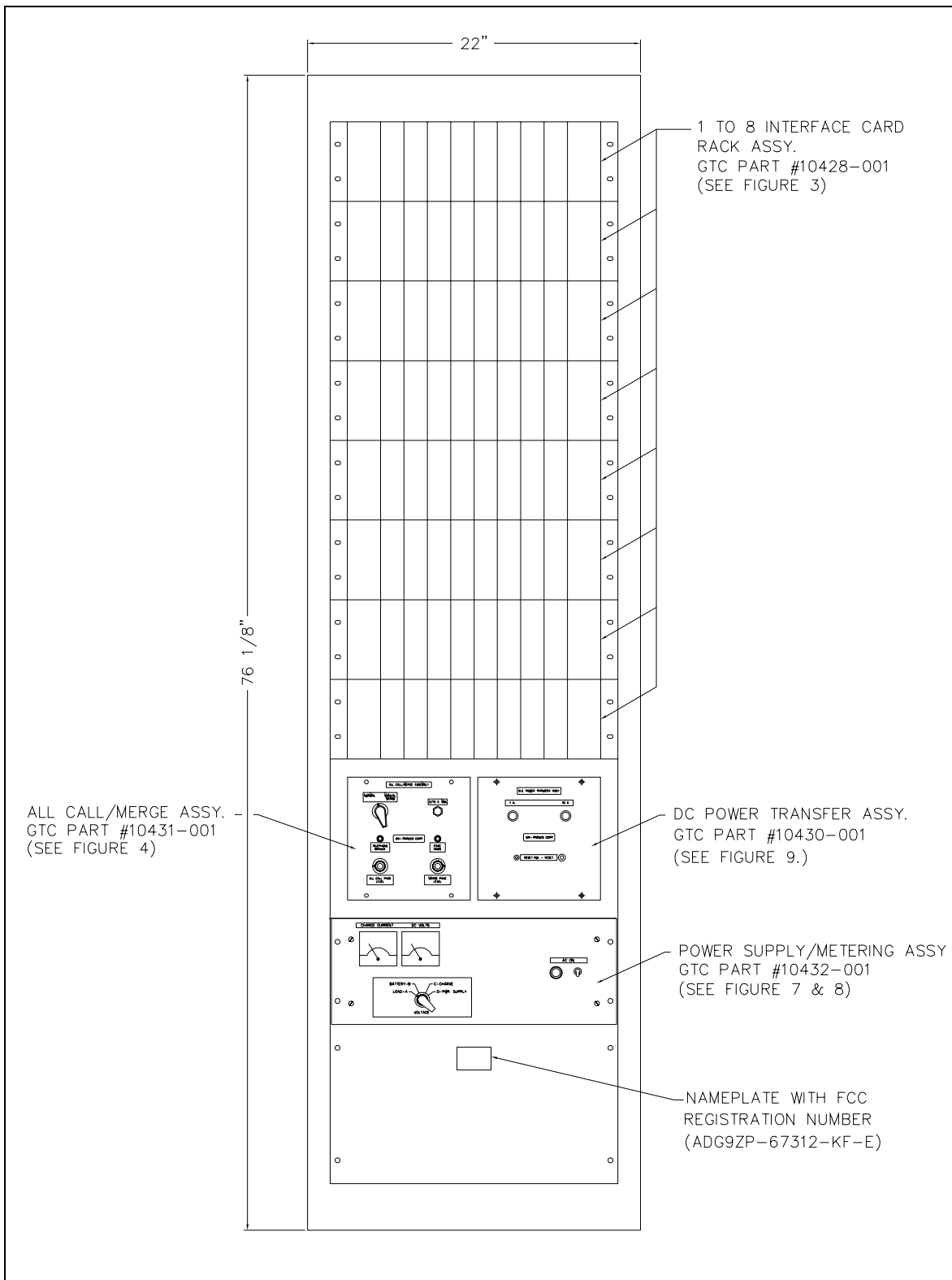

Figure 2. Model 495-001 Telephone Interface Cabinet Outline

The Model 495-001 Phone Interface Cabinet contains the following items:

Qty	Part No.	Description
8	10428-001	PCBA Rack Assembly (each holding ten Telephone Line Interface Assemblies)
1	10432-001	Power Supply/Metering Panel Assembly
1	10431-001	All-Call/Merge Assembly
1	10430-001	DC Power Transfer Assembly
1	10429-001	Housing for All-Call/Merge and DC Transfer Assemblies

Each PCBA Rack assembly occupies the space of a 5.25 × 19-inch rack panel and includes four terminal blocks on the rear surface. The four terminal blocks include two marked **DIAL/PAGE PHONE LINES** to connect ten pairs of wires from ten Mine Dial/Page Phones; and two marked **TELEPHONE LINES** to connect ten pairs of wires to the telephone switchboard. See Figure 3.

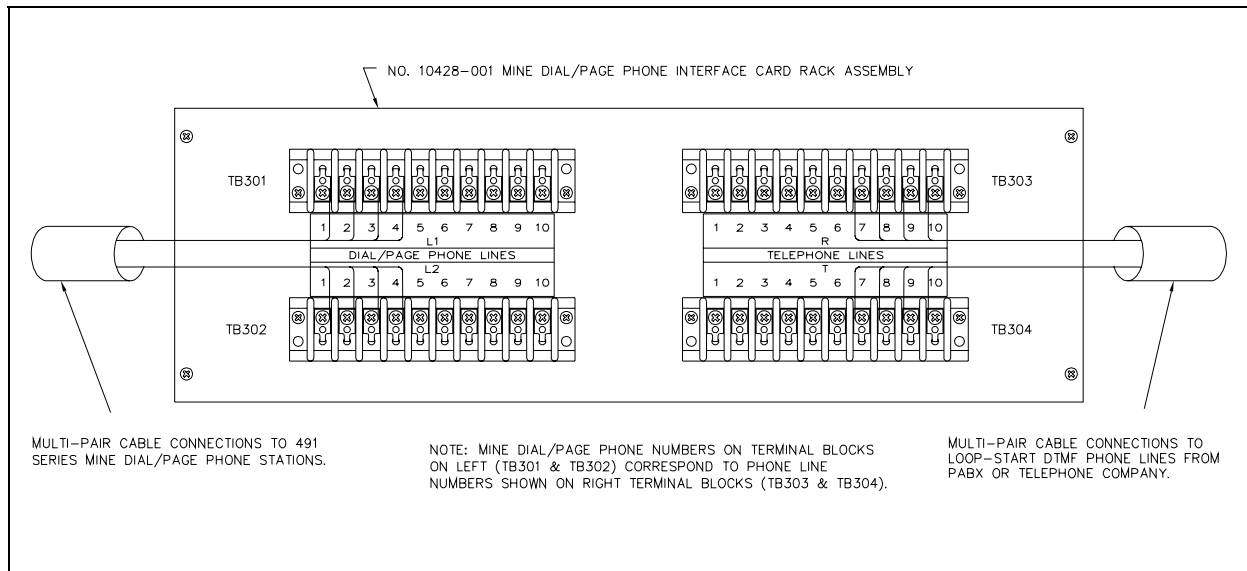

Figure 3. Wiring Diagram for 10428-001 Dial/Page Phone Interface Card Rack Assembly

The line number of a **DIAL/PAGE PHONE LINES** is coordinated with the **TELEPHONE LINES** number and the Interface Assembly position. Mine Phone Line 1 and Telephone Line 1 are both wired to the Interface assembly plugged into slot 1. A fifth terminal block inside the PCBA Rack assembly is used to interconnect multiple rack assemblies and to connect to the All-Call/Merge assembly.

The All-Call/Merge assembly allows all-station paging in the normal dial access, or in the event of a telephone switchboard failure, system-wide paging with push-button page switches on the 491 Series Phone front panel. This assembly includes an audio amplifier and three relays, and is built on an 8-inch square plug-in chassis plate. Refer to Figure 4.

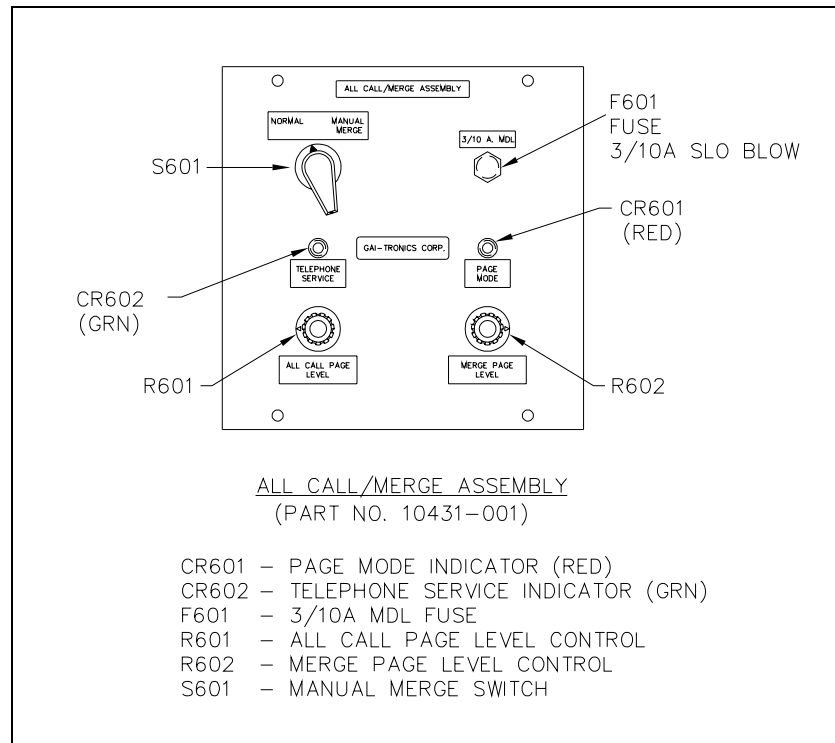

Figure 4. All Call/Merge Assembly 10431-001

DC power to operate the interface circuitry ordinarily comes from an ac-operated power supply located within the Power Supply/Metering Panel assembly. See Figure 8 and Figure 9. Space is provided within this assembly for a rechargeable, non-liquid, lead acid 12 V battery. The battery backs up the system in the event of power supply failure or ac power source failure. The Power Supply/Metering Panel assembly contains meters and switches to indicate the state of the power supply and battery. The assembly occupies the space of a 7 × 19-inch rack panel.

The battery charging circuit and power supply to battery switching system is packaged separately in the DC Power Transfer assembly. This assembly is built similar to the All-Call/Merge assembly for service by substitution and mounts within the housing. See Figure 10.

The housing for All-Call/Merge and DC Transfer assemblies occupies the space of a 10.5 × 19-inch rack panel and houses the two assemblies described above. The housing includes four terminal blocks for input/output connections. See Figure 7.

Installation

Location of the Model 495-001 Interface Cabinet

The interface cabinet is **not** rated as “permissible” by **MSHA regulations** and should be located:

1. Outside the coal mine as close as possible to the point where the cable into the mine emerges from underground (to avoid, or at least minimize, locating this cable out-of-doors).
2. As close as possible to the center of mine operations and/or point of personnel entry.
3. Within a weather-tight, but ventilated building with a reliable source of 120 V, 60 Hz, ac power (15 A minimum).

In a mine-shaft installation, the interface cabinet ideally should set on top of the cable installation bore hole. Typically, it is installed near the elevator shaft or entry slope. If possible, the Model 495-001 Interface Cabinet should be located at the site of the PABX telephone switchboard, but this is not required. The interface cabinet includes a merge function so that if the PABX telephone switchboard or the cable between it and the interface cabinet fails, the GAI-Tronics Mine Dial/Page Phone system automatically switches to an all-stations-merged operation.

Cable and Lighting Requirements

Multiple conductor cable made up of No. AWG 19 twisted pairs with an overall electrostatic shield is recommended to connect the interface cabinet to distribution points inside the coal mine. This cable is typically available with 3 to 100 pairs. The larger sizes are used for the initial link from the interface cabinet into the first main distribution point. The progressively smaller cables can be used for intermediate and final distribution points.

The cable system for a typical 80-station system is shown in Figure 5. The drawing shows the use of 100, 50, 25, and 6-pair cable. Spare conductor pairs in all main distribution cables provide for future expansion. Cable with an integral messenger wire, commonly called “figure 8 cable,” simplifies installation.

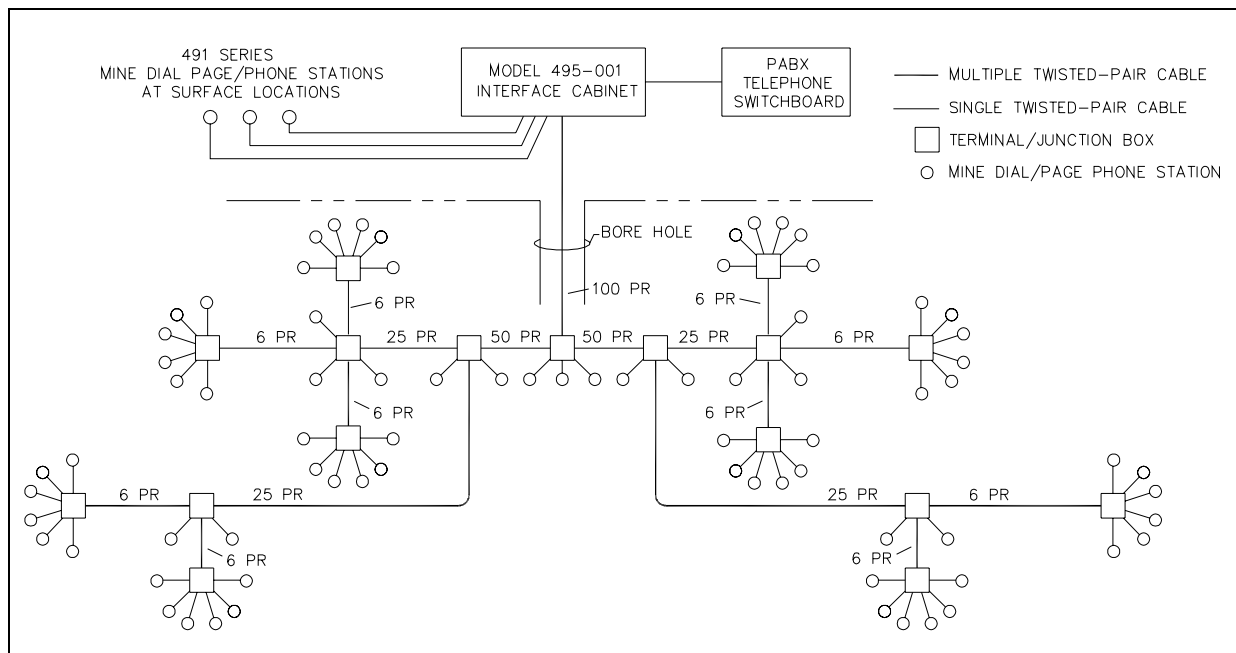

Figure 5. Typical 80-Station Mine Dial Phone Cable System

Single-pair cables can be used to connect each 491 Series Mine Dial/Page Phone to the nearest distribution point. For distances up to one mile, unshielded twisted wire can be used. Shielded cable should be used for longer distances and in situations where the cable is routed near ac power distribution facilities, ac-to-dc rectifiers, or cables.

All underground cables should be installed in accordance with **Federal requirements 30 CFR 75.516-2** and any applicable state requirements. **The location of stations at main portals and working sections must be in accordance with Federal requirements 30 CFR 75.1600** and any applicable state requirements.

If the mine cable (not in metal conduit) is exposed aboveground out-of-doors; adequate line-to-ground transient protection, such as nominal 450 V carbon air-gap lightning arrestors, must be installed between each conductor and ground.

The U.S. Code of Federal Regulations (30 CFR 75.521) requires arrestors within 100 feet of the point a circuit enters a coal mine and that they be grounded separately from power system grounds. Similarly, 30 CFR 77.508 requires arrestors on exposed wires entering buildings at the point of entry.

Except where splices or connections are necessary outside the mine to meet this arrestor requirement, the mine cable must run one continuous length from the point of connection to the interface cabinet. This continuous cable run is a requirement for the system permissibility rating. The continuous cable is necessary because transient line-to-line protection for the mine cable is provided within the interface cabinet PCBA Rack Assembly between the pair of lines to each 491 Series Mine Dial/Page Phone. This arrestor installation limits the coupling of transients that might appear across the pair of wires to each phone.

PABX Telephone Switchboard Requirements

The GAI-Tronics Mine Dial/Page Phone system uses a loop start DTMF (Dual Tone Multi Frequency) line for each independent 491 Series Mine Dial/Page Phone station. In most situations, a Private Automatic Branch Exchange (PABX) at the coal mine site best provides this function.

There are no special requirements for this PABX, and conventional telephones at aboveground locations can also be used with the PABX. This PABX can be provided by a public telephone company, leased or purchased from an "interconnect" telephone equipment company.

The PABX should provide a standard two-wire loop-start 48 V dc analog line connection with bridged ringing (17 to 67 Hz) for each Mine Dial/Page Phone extension. Three additional lines will be required for Monitor and All-Call functions. Refer to Installation section under "Wiring Telephone Interface Cabinet to Telephone System" on page 9 for detailed information.

We recommend that the PABX switchboard have standby batteries in the event of an ac power outage; however, this is not a requirement. Lightning protection should be provided for the PABX per the manufacturer's recommendation.

Connecting AC Power to the Rack

The Model 495-001 requires a 15-amp, single phase, 60 Hz, 120 V ac power source. The cable should be routed through the underside of the 19-inch rack assembly and connected to the duplex outlet in the bottom rear of the rack. Use an appropriate cable clamp (Romex, BX, etc.) for installation.

Connect the white wire from the power cable to the orange/black wire on the outlet. The black wire from the power cable should connect to the red wire on the outlet. All ac circuits within the rack are pre-wired to this outlet.

⚠ CAUTION ⚠ Be sure the AC ON switch on the front panel is of the Power Supply/Metering/ Panel assembly is in the down (Off) position before applying ac power.

Using Voltage Other than 120 V AC

NOTE: As an alternative, the Model 495-001 Interface Cabinet’s power supply can be wired for other input voltages, including a 240 V ac input. Refer to Table 1 and Figure 6.

⚠ CAUTION ⚠ Disconnect all power from the unit before changing input voltage. Be sure to change the primary fuse from 2 A for 120 V ac input to 1 A for 240 V ac input.

Table 1. Input AC Connections (See Case C Diagram)

For use at:	Connect:	Apply ac to:	Primary fuse:
100 V ac	1-3, 2-4	1 and 5	2.0 amp/ 125 V
120 V ac	1-3, 2-4	1 and 4	2.0 amp/ 125 V
220 V ac	2-3	1 and 5	1 amp/ 250 V
230 V ac	2-3	1 and 4	1 amp/ 250 V
240 V ac	2-3	1 and 4	1 amp/ 250 V

NOTE: Connect sense leads -S to -Out and +S to +Out.

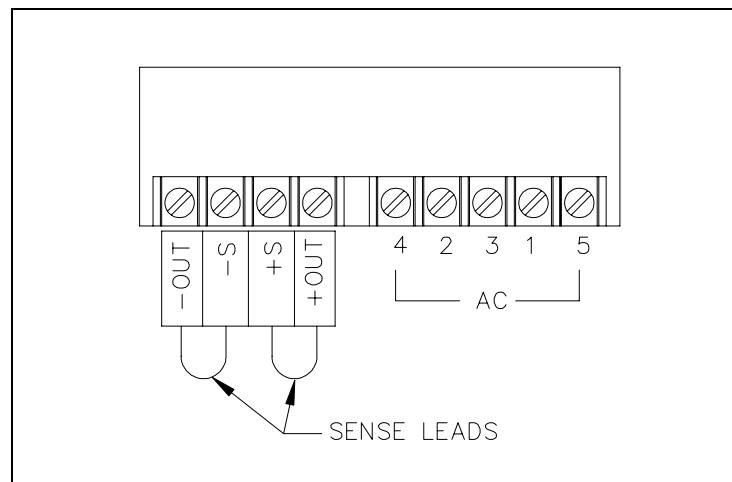

Figure 6. Case C

Wiring Telephone Interface Cabinet to the Telephone System

The Mine Dial/Page Phone Interface Card Rack assembly is connected to telephone line drops from a customer-provided PABX, or directly to leased telephone company lines. The Mine Dial/Page Phone system is designed to operate with any loop-start two-wire telephone line with bridged ringing.

Refer to Figure 3 for wiring details. Screw terminal barrier blocks are provided for telephone line connection.

NOTE: Telephone line connections are not polarity sensitive. In addition to a line (a pair of wires) for each station from the PABX to the interface cabinet, three additional lines (pairs of wires) are required for these system functions. See Figure 7 for wiring details.

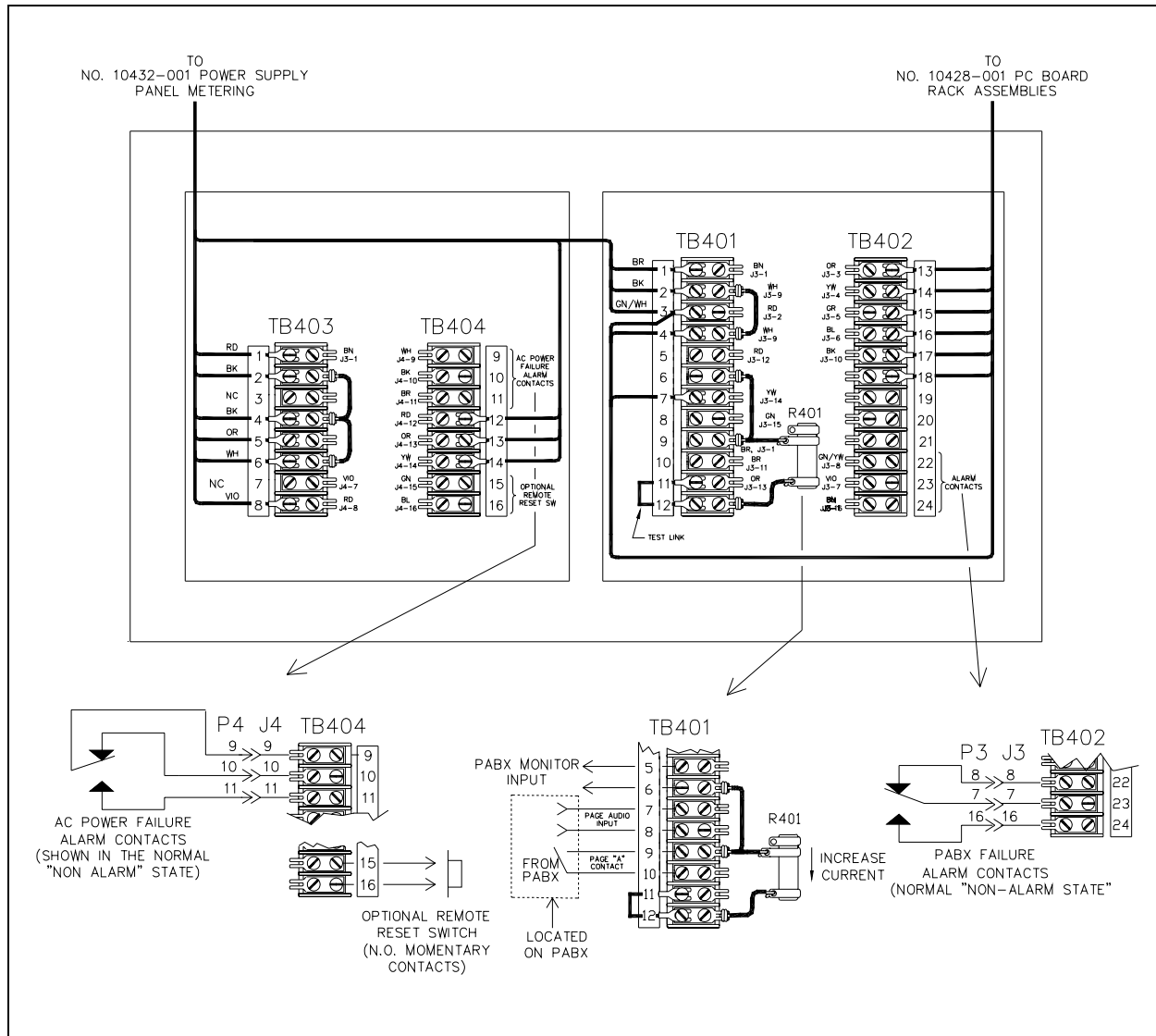

Figure 7. MDPP1 Wiring Information

Monitor (One Pair)

This function is to supply approximately 20 mA dc to a relay in the interface cabinet that when interrupted, switched the system into a merged operation. The nominal 48 V dc power available in most switchboards can be used. Up to 1600 ohms series resistance can be tolerated. An adjustable resistor in the interface cabinet, in series with the relay, can be set to limit the current if the 48 V dc is used directly. An unused station line can also be used to supply this function. See "Adjustment of Switchboard Monitor Circuit" on page 14 for details.

NOTE: The Monitor function **must** be connected for proper operation of the Mine Dial/Page Phone system.

All-Call (Two Pair)

This function is taken from the paging capability built into, or provided optionally by, the PABX. One pair from the PABX provides an "A" relay contact (normally open) and the other provides an audio paging signal at normal telephone line level. The "A" contact will have to switch the positive leg of the monitor voltage into an electronic relay circuit. Maximum current through the contact will be 30 mA dc. See Figure 7.

The supplier of the PABX should install cable(s) for the station lines and the special lines to a termination panel adjacent to the interface cabinet. Barrier terminal blocks are provided on the MDPP system for the telephone line connection.

Wiring Mine Cable to the Interface Cabinet

The cable from the Mine Dial/Page Phone stations should be routed up the left side of the cabinet as seen from the rear. The wires in this cable connect to terminal strips marked MINE PHONE LINES. One wire of each pair goes to a L1 terminal and the other goes to the corresponding L2 terminal immediately below it. **Proper polarity must be maintained in wiring this circuit.** Where black and white coded wiring is used, the white wire should be for L1 and black for L2. Refer to Figure 3.

The wiring within each PCBA Rack Assembly is such that the Interface PCBA Assembly in the number one position completes a circuit from TELEPHONE LINES number one to MINE PHONE LINES number one. The 491 Series Mine Dial/Page Phone No. 1 terminals will have the telephone number (extension number) of the PABX line connected to TELEPHONE LINES No. 1 terminals on the same rack.

Any above ground 491 Series Mine Dial/Page Phone should be wired with the MINE PHONE LINES terminal in the same fashion as those in the hazardous area. The precaution on transient voltage suppressers also applies to the installation of these stations.

AC Power Connection - 120 V ac, 60 Hz, should be brought into the receptacle box at the rear near the floor of the cabinet. All ac-operated circuits within the interface cabinet are pre-wired to this receptacle box. The power line to the interface cabinet should have an independent 15-amp (minimum) line. Be sure the AC ON switch on the front panel of the Power Supply/Metering Panel Assembly is in the down (off) position before applying ac power. See Figure 8.

 **CAUTION**  **Line-to-ground transient protection (such as nominal 450 V carbon/air-gap or gas-tube lightning arrestors) must be installed on all PABX and 491 Series Mine Dial/Page Phone lines exposed above ground.**

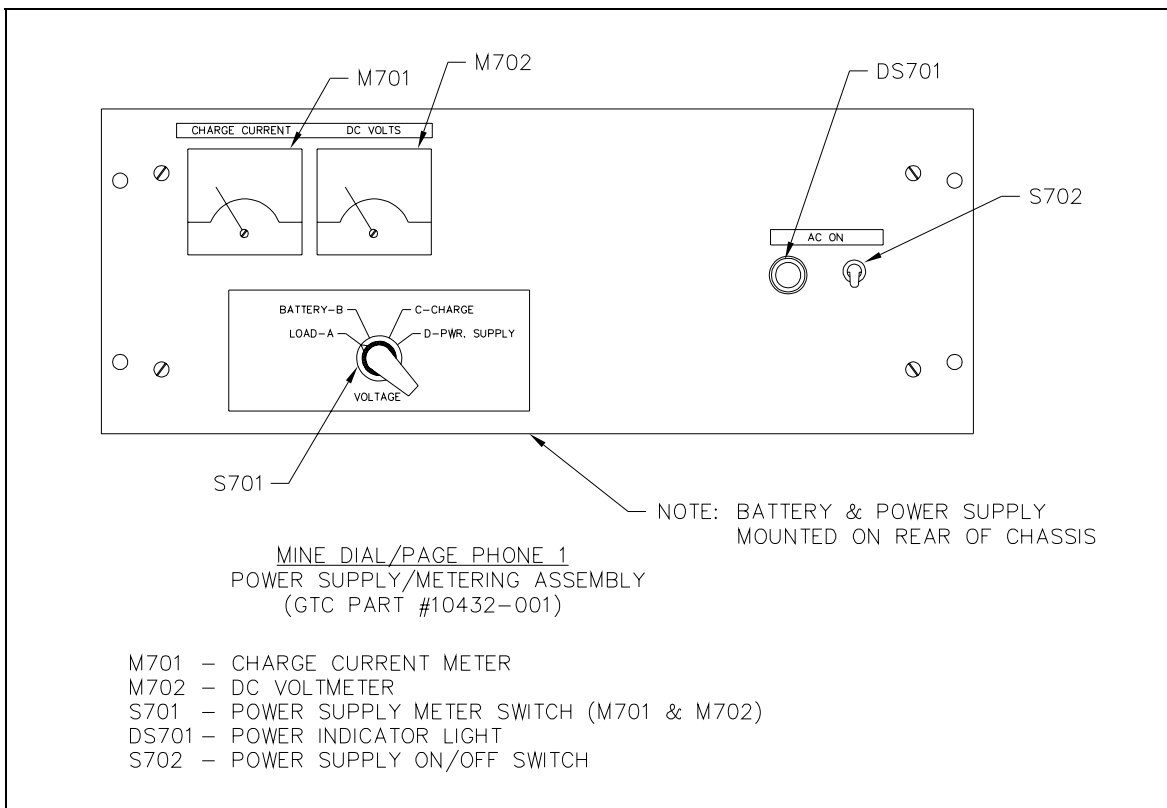

Figure 8. Power Supply

System Check-Out

Wiring to the Telephone Switchboard

All connected telephone pairs, tip and ring, should have approximately 48 V dc across them at the interface cabinet terminals, measured without the Interface PCBA assemblies installed.

AC Power Supply/Metering Assembly and Battery Installation

NOTE: The ac power supply/battery charger should be powered-up and checked out prior to the connection of the battery. Care should be taken to ensure that the battery connectors are not shorted together or to the chassis before the unit is connected to ac power.

Install the stand-by battery in the rear of the Power Supply/Metering assembly as shown in Figure 9. Connect the orange wire to the battery negative (-). Allow the yellow wire to remain disconnected until power supply has been checked out.

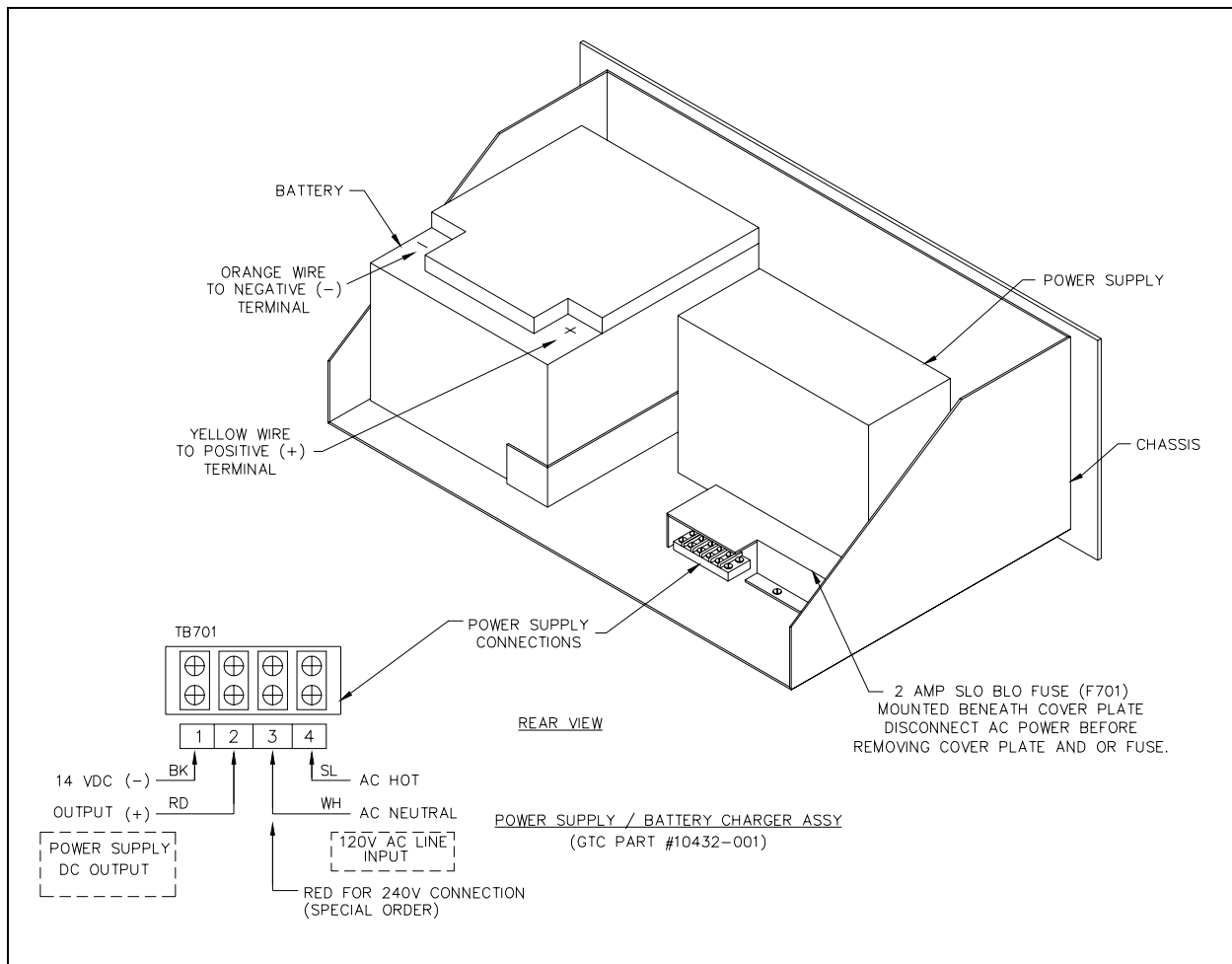

Figure 9. Power Supply/Battery Charger Assembly

The All-Call/Merge assembly and the DC Power Transfer assembly should be installed and secured in their respective enclosures before power is applied to the system. See Figure 4 and Figure 10.

Disengage all of the Plug-in Line Interface cards from their respective sockets prior to the application of power. The system should be connected to a 120 V ac power source, but other input voltages are possible. See the “Connecting AC Power to Rack” section on page 8 for details.

Set S701 to the D-PWR. SUPPLY position and turn on (up position) S702 on the Power Supply. See Figure 8. The amber indicator light (DS701) on the front panel should be lit. The dc voltmeter (M702) of the front panel should indicate approximately 14 V dc and the charge current (M701) meter should read 0 amp current flow.

Carefully insert the Plug-in Line Interface cards into the rack one at a time observing the front panel voltmeter. Each time a card is installed, the power supply voltage will dip slightly and return to 14 V. Each card should draw about 5 mA as indicated on the Power Supply/Metering assembly ammeter. If the power supply voltage remains below 14 V, or a line interface card draws more than 10 mA, the Line Interface card is defective and should be replaced.

Connection and Check-out of Stand-by Battery

After the power supply/battery charger has been installed and checked out, connect the yellow wire from the Power Supply/Metering assembly to the battery positive (+) terminal as shown in Figure 9. Turn the voltmeter switch to the “B-Battery” position. The voltmeter (M702) should read about 12 V.

The battery should start charging with several hundred mA of current as indicated by the large current meter (M701) on the front panel of the Power Supply Metering assembly. The charge current will slowly drop to below 100 mA as the battery nears full charge.

AC Power Failure Alarm Reset and Reset Switch

The green reset indicator (CR504) on the front panel of the DC Power Transfer assembly should be off and the ac power failure relay contacts will be in the alarm state. See Figure 7 and Figure 10. Press the reset switch (S501) to reset the power failure alarm relay and light the reset indicator.

The voltmeter on the front panel of the Power Supply Metering Panel assembly should now indicate about 12 V in all four positions of the meter switch. Positions A, B, C, and D always show 14 V from power supply.

Adjustment of the Switchboard Monitor Circuit

Current to operate the switchboard monitor relay within the All-Call/Merge assembly is controlled by an adjustable resistor attached to terminal block TB401 on the enclosure for the All-Call/Merge assembly. See Figure 7. Because the current also varies with the resistance of the telephone switchboard cable, this resistor is adjusted to compensate for this cable loss.

In normal operation, the switchboard monitor relay is continuously energized and the green indicator light on the front panel of the All-Call/Merge assembly is illuminated. To set the adjustable resistor properly, it is first necessary to find the critical point; if the light is on, increase resistance until it goes off. Or, if the light is not lit, decrease resistance until it does light. Then, as a safety factor, decrease the resistance by about 25%.

The monitor relay current can be measured by temporarily replacing the "test link" between terminals 11 and 12 on TB401 with an ammeter. See Figure 7. The current should be between 20 and 40 mA when properly adjusted. The monitor relay contacts are rated for 2 amps, 28 V dc/120 V ac.

Check-Out of Optional Alarm Circuit

Relay contact outputs are provided for ac power failure alarm (TB404-9, 10 and 11) and PABX failure alarm (TB402-22, 23 and 24). These relay contacts can be used to activate audible/visual alarms such as bells or strobe lights as required. See Figure 7 for wiring details. These relay contacts are rated for 2 A, 28 V dc/120 V ac.

Check-Out of Operation and Adjustment of All-Call Mode

1. Activate the All-Call page by following the instructions outlined in Operation section on page 15.
2. Observe that the red PAGE MODE indicator on the All-Call/Merge assembly is lit during operation in this mode.
3. Adjust the ALL-CALL PAGE LEVEL control on the front panel of the All-Call/Merge assembly so that the speaker level at a 491 Series Mine Dial/Page Phone is the same in this model as in the normal individual station call mode.

Operation

Answer Incoming Calls at a Mine Dial/Page Phone Station

1. Wait until the “birdie” call stops and allow calling party sufficient time to announce the desired person’s name.
2. Lift handset from the cradle and depress the handset pressbar. Reply to calling party. Do not release pressbar at any time during conversation or conversation will be terminated.
3. Release pressbar to terminate call. Return handset to cradle.

Initiating Calls at a Mine Dial/Page Phone Station

To call another Mine Dial/Phone station:

1. Depress the handset pressbar and listen for dial tone; hold.
2. Dial desired telephone number.
3. Wait until the “birdie” signal stops, then page desired person(s).
4. If no answer after approximately 30 seconds, terminate call (called person’s telephone connection returns to ready condition after approximately 30 seconds).
5. Release handset pressbar to terminate call.

Merge Mode Operation: The Mine Dial/Phone system automatically transfers to this mode in the event of switchboard failure.

1. Depress and hold handset pressbar - no dial tone will be heard.
2. Push and hold EMERGENCY PAGE button.
3. Page desired person(s).
4. Release the button and wait for an answer. **NOTE:** Conversations are not private; any number of persons can use the party line simultaneously in the same conversation.
5. Release handset pressbar to terminate call.

To page all Mine Dial/Page Phone stations:

1. Depress handset pressbar and listen for dial tone; hold.
2. Dial special page number.
3. Immediately page desired person(s) giving message or call-back instructions (paged person cannot answer directly).

To call a standard telephone station:

1. Depress handset pressbar and listen for dial tone; hold.
2. Dial desired telephone number.
3. Wait until called person answers, and then talk.
4. Release handset pressbar to terminate call.

Initiating Calls at a Standard Telephone to a Mine Dial/Page Phone

To call one specific station:

1. Dial the telephone number in the normal fashion.
2. Wait until "birdie" signal stops, then page desired person(s). Allow called party 30 seconds to answer. If there is no answer within 30 seconds, the switchboard connection is automatically terminated and the called person's telephone connection returns to a ready condition.
3. Hang-up telephone in normal fashion to terminate call.

To page someone at all stations:

1. Dial the special page number in the normal fashion.
2. Immediately page desired person(s) giving message or call-back instructions (paged person cannot answer directly).
3. Hang up telephone immediately.
4. Wait for return call.

System Troubleshooting Procedure

Power Supply/Metering Panel Alarm Indicating Faults

Refer to Figure 8. If the green RESET INDICATOR lamp (**CR504**) on the DC Power Transfer assembly panel is not lit:

1. Check for presence of ac line voltage. The amber AC ON lamp (**DS701**) on the Power Supply/Metering Panel should be lit. If it is not lit, check power switch (**S702**) and ac supply line.
2. Press RESET button on panel of DC Power Transfer assembly. See Figure 10. If ac power has been temporarily interrupted, the RESET INDICATOR should turn on and the alarm system should turn off.
3. Turn VOLTAGE switch (**S701**) on the Power Supply/Metering Panel assembly to LOAD-A position. A reading in the vicinity of 12 volts on the DC VOLTS meter (**M702**) indicates the system is operating, possibly by obtaining all operating current from the battery.
4. Turn switch to D-PWR.SUPPLY position. If the DC VOLTS meter now indicates zero or near zero voltage, even with the presence of ac line voltage, the internal power supply may be defective, or the ac fuse may be blown. The ac line fuse is a 2 A slo-blo (**F701**) fuse located in the rear of the Power Supply Metering assembly under a cover plate. Refer to Figure 9. The cover plate must be removed to access the fuse.
5. If the system is not operating, check battery voltage indications on DC VOLTS meter by turning VOLTAGE switch to BATTERY-B position. Also, compare reading with switch in C-CHARGE position. If it is not the same, check 10 A fuse (**F502**) on panel of Power Transfer assembly. See Figure 10.

Battery Charging Check-out after AC Power Outage

Battery charging current as indicated on CHARGE CURRENT meter (M701) on panel of Power Supply/Metering Panel assembly after restoration of ac power can be as high as ½ amp depending on length of outage and prior battery condition. If there is no indication of charge current, check both fuses on the front panel of DC Power Transfer assembly. See Figure 10.

If green TELEPHONE SERVICE lamp (CR602) on All Call/Merge Assembly is not lit:

1. Check operation of telephone switchboard using a conventional telephone, preferably one connected to the switchboard via same cable used for the Mine Dial/Page Phone System.
2. Check switchboard monitor voltage on terminals 5 and 6 of terminal board **TB401** using dc voltmeter (positive on 6). If higher than normal, check **R401** and test link on same terminal board (**TB401**). Also, check indicator light itself (**CR602**) and relay (**K653**) located within the All-Call/Merge assembly. Refer to Figure 7.

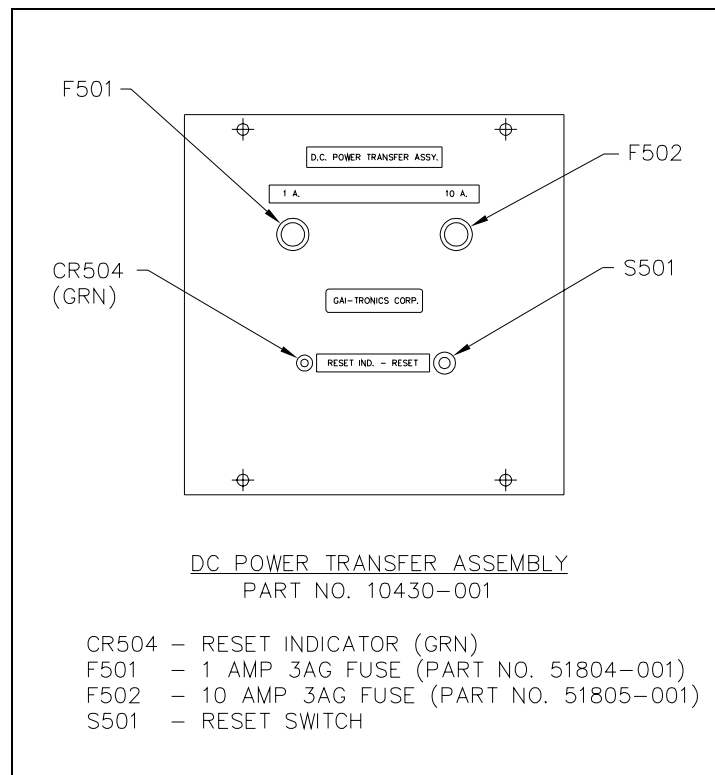

Figure 10. DC Power Transfer Assembly 10430-001

Other Faults

If one Mine Dial/Page Phone Station is out of normal service:

1. Substitute known good Plug-in Line Interface card in the appropriate Interface Card Rack, if calls to that station produce busy or continuous ringing response (instead of “birdie” signal in receiver of calling station).
2. Substitute known good Mine Dial/Page Phone if calls to that station produce normal response in receiver of calling station. Before entering hazardous area it may be preferable to test operation to known good unit temporarily tied across corresponding MINE PHONE LINES terminals in back of interface cabinet.
3. Substitute known good Mine Dial/Page Phone in place of regular unit.
4. Check lines between location of Mine Dial/Page Phone and interface cabinet.

If all Mine Dial/Page Phone Stations are out of normal service:

1. Check for presence of dc power to Line Interface Card Racks.
2. Check for blown fuse (**F501** or **F502**) or other defect in the DC Power Transfer assembly. See Figure 10.

If All-Call function does not operate (but switchboard does operate for dialed calls) check operation of or substitute the All Call/Merge Amplifier assembly.

General

Wiring shall be installed so as to assure that there is adequate insulation of telephone wiring from commercial power wiring and grounded surfaces. Wiring is required under these rules either to be sheathed in an insulating jacket, in addition to the insulation enclosing individual conductors, assured that **this physical and electrical protection is not damaged or abraded during placement of the wiring.** Any intentional removal of wiring insulation for connections or splices shall be accomplished by removing the minimum amount of insulation necessary to make the connection or splice, and insulation equivalent to that provided by the wire and its jacket, or its enclosure, shall be suitably restored, either by placement of the splices or connections in an appropriate enclosure, or by using adequately insulated connections or splicing means.

Building and Electrical Codes

Telephone wiring shall comply with all applicable building and electrical codes in the local jurisdiction. If there are no such codes applicable to telephone wiring, **comply with Article 800 of the National Electrical Code (NEC), entitled Communications Systems, and other applicable sections of that Code incorporated therein by reference.**

Physical Protection

In addition to the general requirements that wiring insulation be adequate and not damage during placement of the wiring, wiring shall be protected from adverse effects of weather and the environment in which it is used. Where wiring is attached to building finish surfaces (surface wiring), it shall be suitably supported by means that do not affect the integrity of the wiring insulation.

Acceptance Test

1. Lift the handset of the Mine Dial/Page Phone and depress the handset pressbar switch to create the off-hook state on the line or loop under test.
2. Listen for noise. Confirm that there is neither audible hum nor excessive noise.
3. Listen for dial tone. Confirm that dial tone is present.
4. Break dial tone by dialing a digit. Confirm that dial tone is broken as a result of dialing.
5. With dial tone broken, listen for audible hum or excessive noise. Confirm that there is neither audible hum nor excessive noise.

Failure of Acceptance Test Procedures

Any of the following present during testing of two-way lines, outgoing lines, or loops indicate failure: absence of dial tone before dialing, inability to break dial tone, presence of audible hum, excessive noise, or any combination of these conditions. Any of the following present during test of incoming-only lines or loops indicates failure: inability to receive ringing, inability to break ringing by going off-hook, presence of audible hum, excessive noise, or any combination of these conditions.

Notice of the Right to Bring a Complaint

In any case where the telephone company invokes these procedures, it shall afford the customer the opportunity to correct the situation which gave rise to invoking these procedures, and inform the customer of the right to bring a complaint to the **FCC**. On complaint, the Commission reserves the right to perform any of the inspections authorized and to require the performance of acceptance tests.

User Instructions (USA)

FCC Information

FCC Registration Number ADG9ZP-67312-KF-E

Ringer Equivalence (REN)0.1B

Network Connection (USOC) Screw Terminal Strips provided for phone line connection

Meets hearing aid compatibility technical standards per FCC Section 68.316

Federal Communication Commission regulations require that the following instructions be adhered to connecting to the US public telephone network. This equipment complies with Part 68 of the FCC rules. On the front panel of this equipment is a label that contains, among other information, the FCC Registration Number and Ringer Equivalence Number (REN) for this equipment.

Your telephone company may make changes in their facilities, equipment, operations or procedures that could affect the proper functioning of your equipment. If they do, you will be notified in advance to give you an opportunity to maintain uninterrupted telephone service.

NOTE: The telephone company may ask that you disconnect this equipment from the network until the problem has been corrected or until you are sure that the equipment is not malfunctioning.

This equipment may not be used on party lines or coin service provided by the telephone company.

Specifications

Model 491 Mine Dial/Page Phone

Line voltage	12 V dc
Supervisory current.....	20 mA dc, maximum
Audio impedance, input	200 ohms, nominal
External controls (two)	Push-to-operate switch (in handset), Emergency page switch (on panel)
Internal controls (two).....	Speaker volume, Sidetone
Microphone	Dynamic, noise-canceling
Speaker.....	Dynamic, horn-loaded
Power supply.....	Internal dry cell battery, 12 V
Page/indicator lamp	Approximately 66 flashes per minute; 6.6% duty cycle

Model 495-001 Interface Cabinet

Number of channels	80 maximum
Audio impedance to switchboard.....	600–900 ohms
Metering	Power supply voltage Load current Battery charging current
Transient isolation-telephone circuit to corresponding mine circuit.....	500 V, minimum
Transient limiter - across mine lines	25 V, peak
Normal power requirements	120 V, ± 10%, 50–60 Hz @ 2 A 240 V, ± 10% @ 1 A, optional
Standby power operation	8 hours, minimum via rechargeable battery

Switchboard Requirements

Station selection	DTMF (Dual Tone Multi Frequency)
Open-circuit voltage.....	48 V dc, nominal
Loop current.....	50 mA nominal, 20 mA minimum
Auxiliary requirements	
Page audio:.....	Nominal 0 dBm, 600–900 ohms
Page control:	A: contact, nor. Open
Monitor:	48 V dc nom. 1200 ohms maximum source/line resistance

FCC Information

FCC Registration #:	ADG9ZP-67312-KF-E
REN #:	0.1B

Warranty

Equipment. GAI-Tronics warrants for a period of one (1) year from the date of shipment, that any GAI-Tronics equipment supplied hereunder shall be free of defects in material and workmanship, shall comply with the then-current product specifications and product literature, and if applicable, shall be fit for the purpose specified in the agreed-upon quotation or proposal document. If (a) Seller's goods prove to be defective in workmanship and/or material under normal and proper usage, or unfit for the purpose specified and agreed upon, and (b) Buyer's claim is made within the warranty period set forth above, Buyer may return such goods to GAI-Tronics' nearest depot repair facility, freight prepaid, at which time they will be repaired or replaced, at Seller's option, without charge to Buyer. Repair or replacement shall be Buyer's sole and exclusive remedy. The warranty period on any repaired or replacement equipment shall be the greater of the ninety (90) day repair warranty or one (1) year from the date the original equipment was shipped. In no event shall GAI-Tronics warranty obligations with respect to equipment exceed 100% of the total cost of the equipment supplied hereunder. Buyer may also be entitled to the manufacturer's warranty on any third-party goods supplied by GAI-Tronics hereunder. The applicability of any such third-party warranty will be determined by GAI-Tronics.

Services. Any services GAI-Tronics provides hereunder, whether directly or through subcontractors, shall be performed in accordance with the standard of care with which such services are normally provided in the industry. If the services fail to meet the applicable industry standard, GAI-Tronics will re-perform such services at no cost to buyer to correct said deficiency to Company's satisfaction provided any and all issues are identified prior to the demobilization of the Contractor's personnel from the work site. Re-performance of services shall be Buyer's sole and exclusive remedy, and in no event shall GAI-Tronics warranty obligations with respect to services exceed 100% of the total cost of the services provided hereunder.

Warranty Periods. Every claim by Buyer alleging a defect in the goods and/or services provided hereunder shall be deemed waived unless such claim is made in writing within the applicable warranty periods as set forth above. Provided, however, that if the defect complained of is latent and not discoverable within the above warranty periods, every claim arising on account of such latent defect shall be deemed waived unless it is made in writing within a reasonable time after such latent defect is or should have been discovered by Buyer.

Limitations / Exclusions. The warranties herein shall not apply to, and GAI-Tronics shall not be responsible for, any damage to the goods or failure of the services supplied hereunder, to the extent caused by Buyer's neglect, failure to follow operational and maintenance procedures provided with the equipment, or the use of technicians not specifically authorized by GAI-Tronics to maintain or service the equipment. **THE WARRANTIES AND REMEDIES CONTAINED HEREIN ARE IN LIEU OF AND EXCLUDE ALL OTHER WARRANTIES AND REMEDIES, WHETHER EXPRESS OR IMPLIED BY OPERATION OF LAW OR OTHERWISE, INCLUDING ANY WARRANTIES OF MERCHANTABILITY OR FITNESS FOR A PARTICULAR PURPOSE.**

Return Policy

If the equipment requires service, contact your Regional Service Center for a return authorization number (RA#). Equipment should be shipped prepaid to GAI-Tronics with a return authorization number and a purchase order number. If the equipment is under warranty, repairs or a replacement will be made in accordance with the warranty policy set forth above. Please include a written explanation of all defects to assist our technicians in their troubleshooting efforts.

Call 800-492-1212 (inside the USA) or 610-777-1374 (outside the USA) for help identifying the Regional Service Center closest to you.